

# NOMEX® and KEVLAR® for Rail Applications

## Parallels between Aerospace and Rail

### DuPont Protection Technologies

*Railway Interiors Expo, Koelnmesse,  
Germany, 26 November 2006*



***Olivier Rozant, PhD*** – Development Manager KEVLAR®, NOMEX® Mass Transportation



*The miracles of science™*

# Agenda

- **Nomex® Honeycombs for Rail Applications**
  - **Characteristics for transportation industry**
  - **Parallels between aerospace and rail**
  - **Applications and benefits**
    - **Structural**
    - **Interiors and design**
    - **Manufacturing**
- **Conclusions**



# Nomex® - Characteristics for Transportation Industry

*“Nomex® - the qualities you need in mass transportation”*

## Filament Yarn



## Staple Fiber

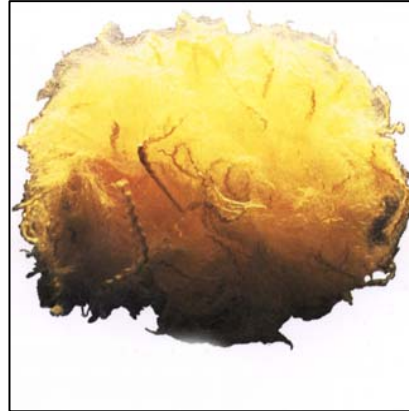

## Paper & Board

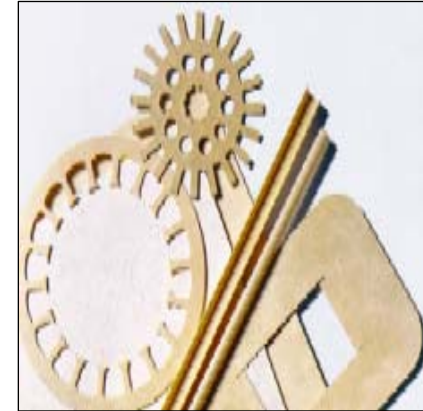

### HEAT RESISTANT

- Self auto-extinguishable
- Does not shrink under heat
- Does not melt / drip
- Starts to carbonize at 425°C to 475° C
- Good heat insulator
- Electrical arc resistance

➤ **Constant quality of production**

### ABRASION RESISTANCE

- 2 times more abrasion resistant than cotton
- Up to 4 times more tear resistant than cotton

### CHEMICALLY RESISTANT

- Resistant to a wide list of chemicals
- Water and oil do not affect the properties

### FLEXIBLE

- Wearing comfort

# Nomex® - Characteristics for Transportation Industry

## Personal Protection



## Electrical Insulation in Transformers & Motors



## Thermal Barriers



## Electronics

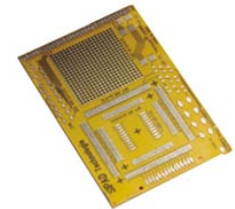

## Gas Filtration



## Composites



## Flame Resist Fabrics





# Agenda

- **Nomex® Honeycombs for Rail Applications**
  - Characteristics for transportation industry
  - **Parallels between aerospace and rail**
  - Applications and benefits
    - **Structural**
    - **Interiors and design**
    - **Manufacturing**
- **Conclusions**



# Nomex® - Parallels between Aerospace and Rail



## Aerospace and Rail have same requirements:

- Mass transportation
- Stringent safety / fire regulations
- Product performances reliability
- Improved efficiency for energy savings
- Enhanced passenger comfort
- Efficient and smart manufacturing

# Nomex® - Parallels between Aerospace and Rail

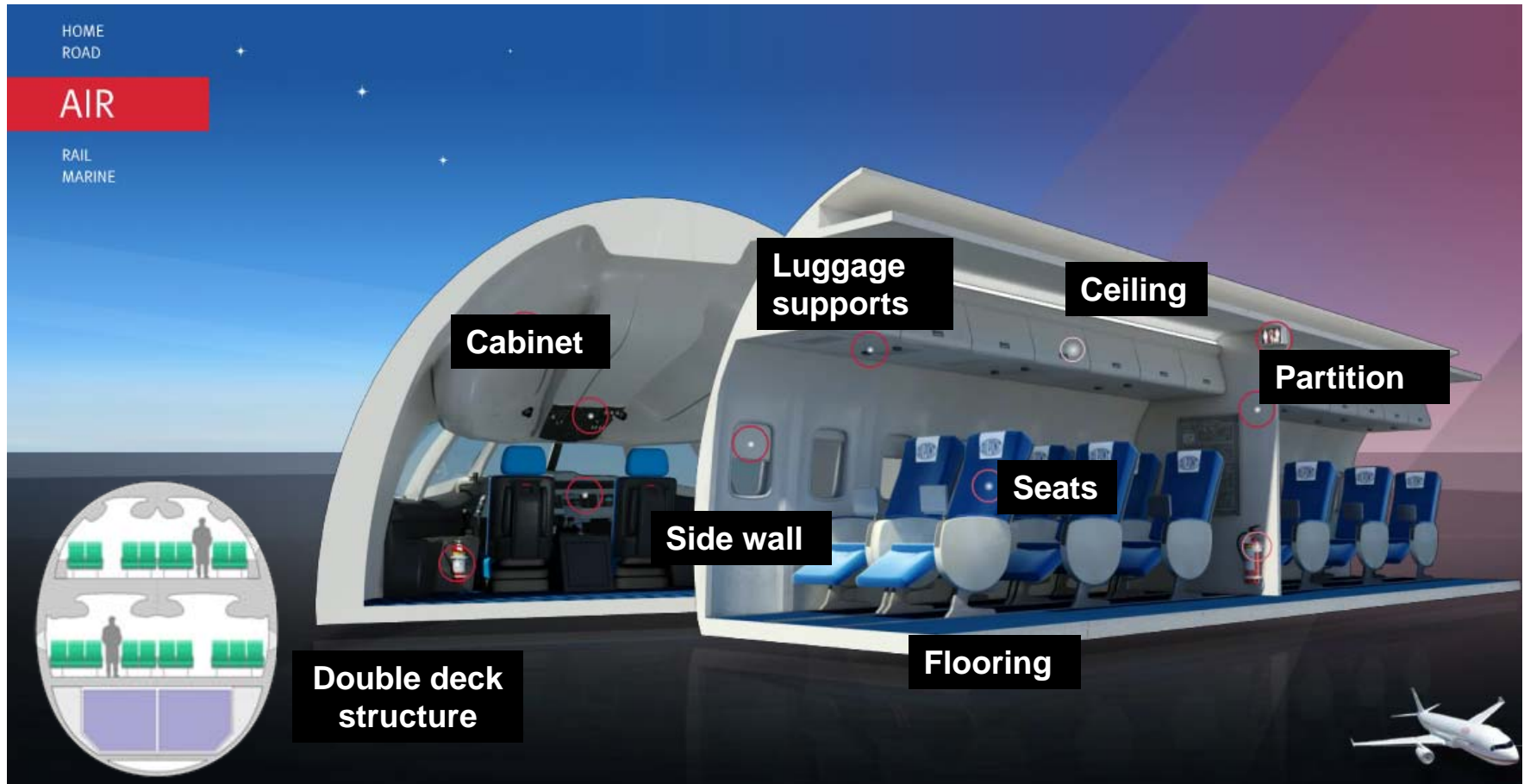

## Parts where Nomex® is used in aircrafts

- Under **honeycombs** for structural / semi-structural parts
- Under **protective fabrics** for its fire resistance

# Nomex® - Parallels between Aerospace and Rail

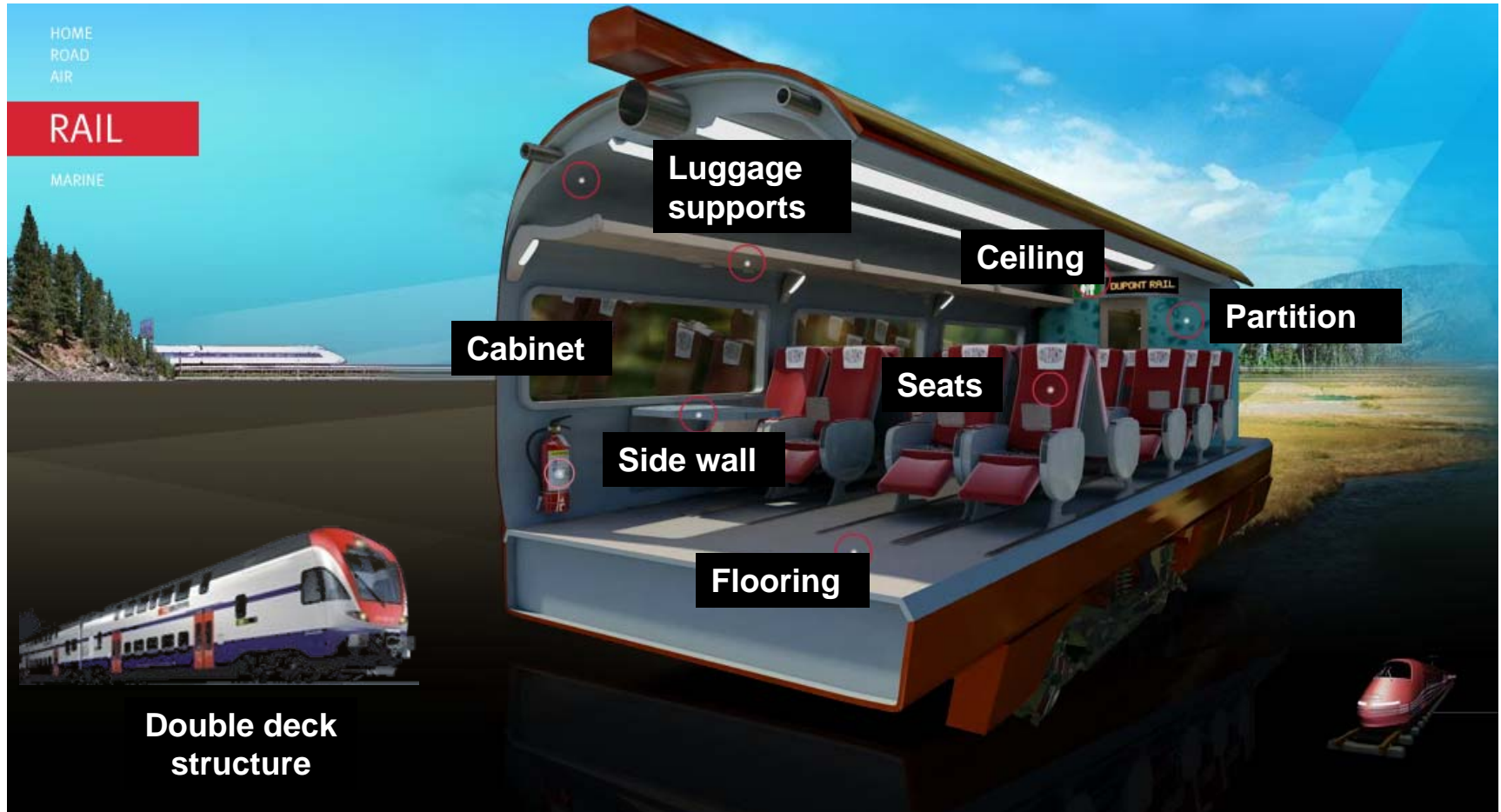

## Aerospace and Rail have same requirements:

- Similar interiors
- Similar performances and functionalities



# Agenda

- **Nomex® Honeycombs for Rail Applications**
  - **Characteristics for transportation industry**
  - **Parallels between aerospace and rail**
  - **Applications and benefits**
    - **Structural**
    - **Interiors and design**
    - **Manufacturing**
- **Conclusions**



# Nomex® - Applications and Benefits

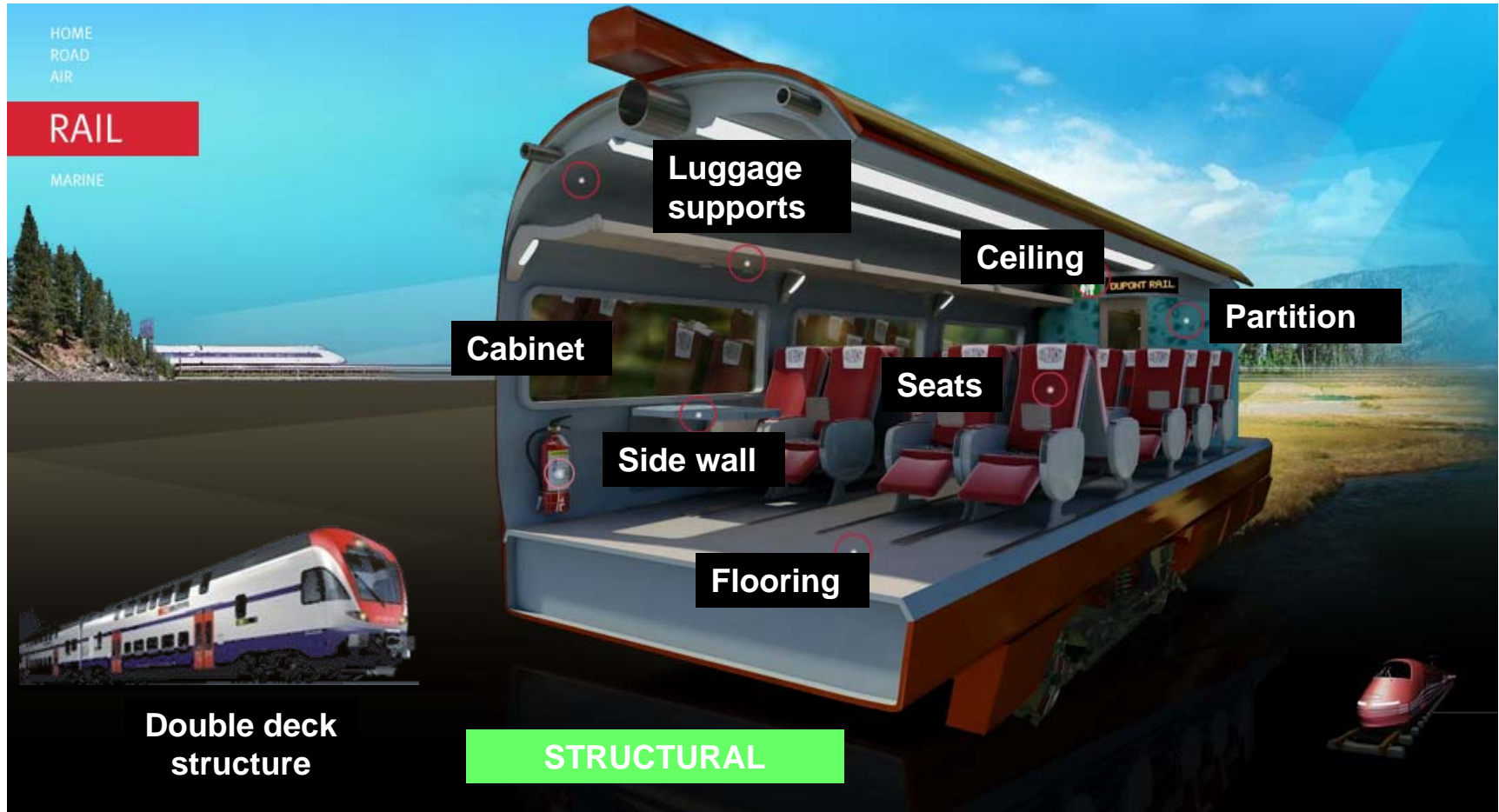

## Aerospace and Rail have same requirements:

- Similar interiors
- Similar performances and functionalities

# Nomex® - Applications and Benefits

*“Nomex® - the qualities you need in mass transportation”*

## Honeycomb cores

- Exceptional stability of stiff hexagonal cells **inspired by nature**
- Honeycomb is a **smart core**
  - **Light**
  - **Strong**
  - **Rigid (sandwich)**
- **Nomex® honeycombs** bring added benefits:
  - **Excellent moisture resistance** = neither fungi nor mold
  - **Chemically inert and non-metallic** = **inherently corrosion resistant**
  - **Heat and flame resistance + self-extinguishing** properties = meet stringent aircraft standards approved in aircrafts
  - **Absorbs noise and vibration** (engine, rolling noises) = enhanced comfort for passengers

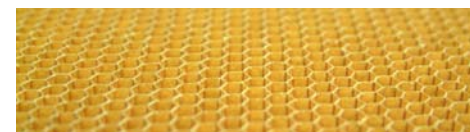

Nomex® honeycomb

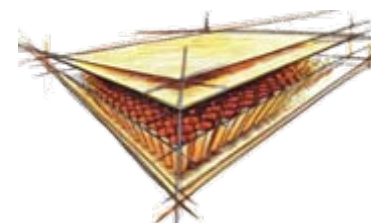

Sandwich structure



26 Nov. 2009, Railway Interiors, Koeln

# Nomex® - Applications and Benefits

*“Nomex® - the qualities you need in mass transportation”*

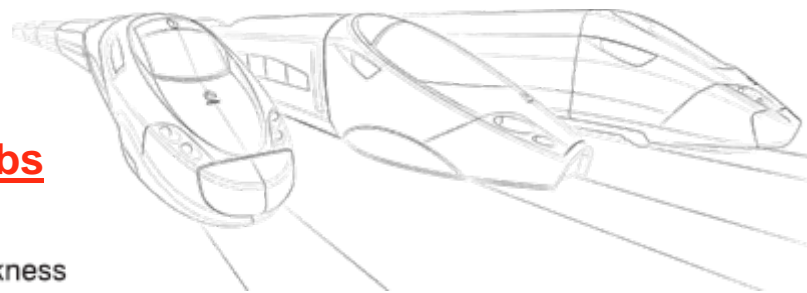

Lightening your loads with smart design

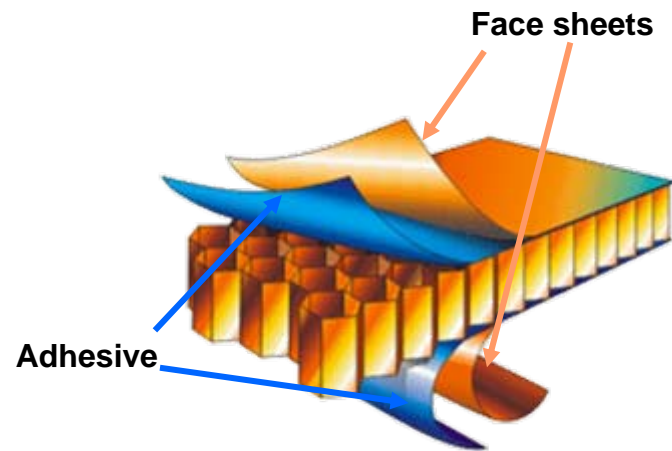

Honeycomb sandwich construction

## Sandwich effect with honeycombs

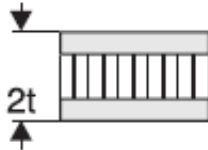
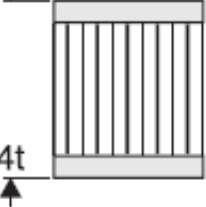
	Solid Material	Core Thickness $t$	Core Thickness $3t$
			
Stiffness	1.0	7.0	37.0
Flexural Strength	1.0	3.5	9.2
Weight	1.0	1.03	1.06

Statistics courtesy of Hexcel

- **Nomex® honeycomb** stiffens and strengthens a structure **without increasing its weight**









# Nomex® - Applications and Benefits

*“Nomex® - the qualities you need in mass transportation”*

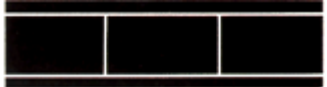

## Structural comparisons for bending loads

Design	Relative strength	Relative stiffness
 Honeycomb Sandwich	100 %	100%
 Foam Sandwich	26	68
 Structural Extrusion	62	99
 Sheet and Stringers	64	86
 Plywood	3	17

*Statistics courtesy of Hexcel*

## Maximum robustness for minimum weight

- **Shear strength**
  - >> foams / balsa / plywood
  - ~ aluminium and glass honeycombs
- **Compressive strength**
  - slightly better than aluminium and wood
  - >> better than rigid foams
- **Toughness** (vs other honeycomb cores)
  - **unique capability** to resist overloads in local areas without permanent damage
  - provide **excellent in-service abuse resistance**

# Nomex® - Applications and Benefits

## Nomex® cored sandwich structures in structural applications

### Benefits

- **Lower weight**
  - Lighter coaches for **improved efficiency** (E, CO<sub>2</sub> credits)
  - **Lower center of gravity** for greater safety and comfort (high-speed, double-decker trains)
  - **Lower inertia** resulting in significant **energy savings** (inter-city, metros, trams)
  - **Lower stresses** reduce **bogie** maintenance
  - **Less wear** and damages on **tracks** for **increased service life**
- **Higher specific stiffness**
  - **Less partitions** and **more interior design flexibility**
  - **Additional seats** or payload capability
- **Intrinsic to Nomex®**
  - Unique **vibrations** and **noise damping** for **better comfort**
  - Better **thermal insulation** – (~ 180 x / Al)



Photo courtesy of Alstom, Bombardier

# Nomex® - Applications and Benefits

## *Parallels between Aerospace and Rail*

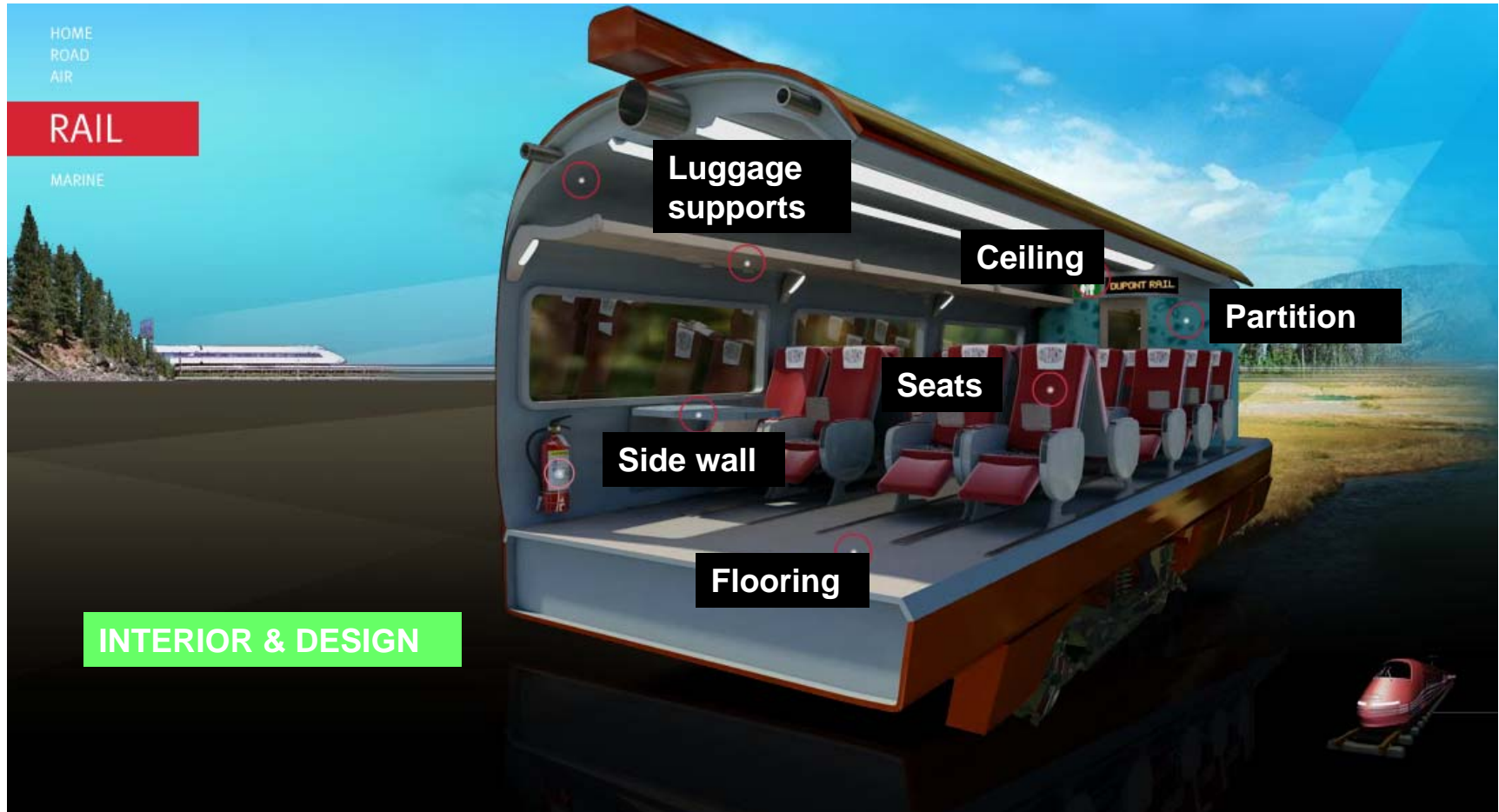

### Aerospace and Rail have same requirements:

- Similar interiors
- Same requirements and functionalities

# Nomex® - Applications and Benefits

*“Nomex® - the qualities you need in mass transportation”*

## Interiors and decorative solutions

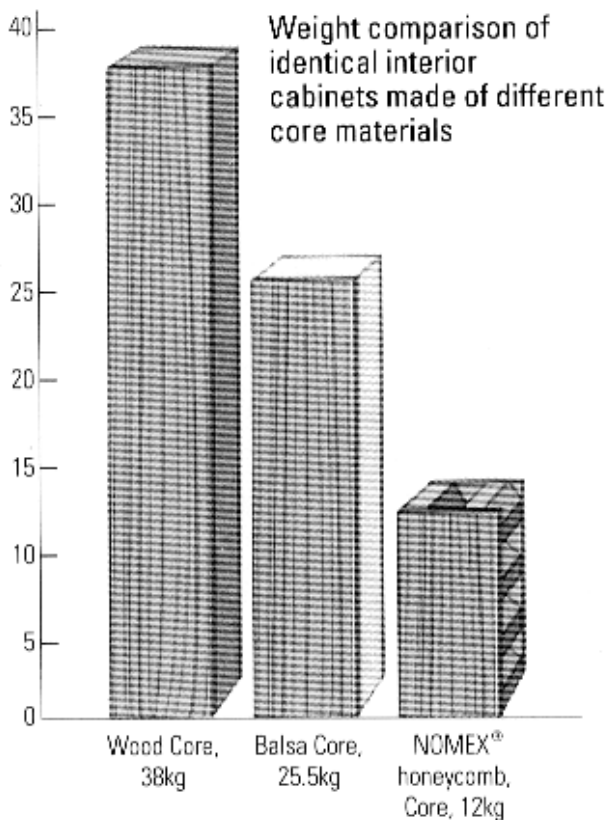

- **Low weight – 60% lighter than all-wood equivalents**
- **Easy to shape** (thermoformable – cells do not collapse)
- Dimensional stability
- **Extremely impact tolerant**
- **Fire resistant** – non-melting, self-extinguishing & low smoke emission
- **Sound, vibration and heat insulation** (enhanced comfort)



Photo courtesy of IFV, TER, Alstom

26 Nov. 2009, Railway Interiors, Koeln



# Nomex® - Applications and Benefits

*“Nomex® - the qualities you need in mass transportation”*

## Interiors and decorative solutions



Easy to shape

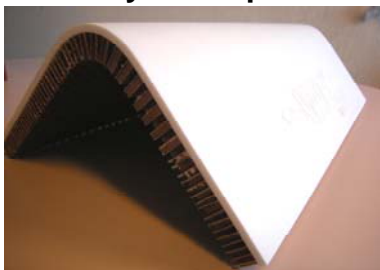

- Let our imagination be your guide
  - Interior furnishing, **partitions**, cupboards,...
  - Staterooms, **cabins**, galleys and bathroom
  - **Tables**, bunks, decks and bulkheads
  - **Doors**, hatches, **ceiling panels** and stairwells

- Additional functionalities

- **Insulation** and **fire resistance**
- Compatible with **Corian®** for **nicer, cleaner and colored surfaces** to beat competition (restaurant coach, lavatories, kitchen)

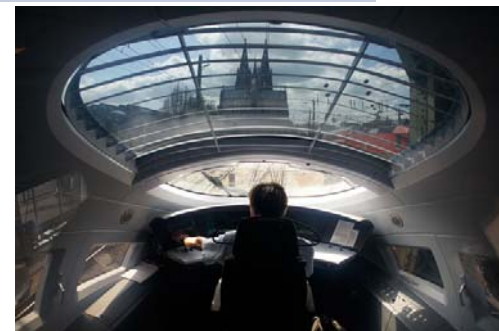

*Photo courtesy of Bombardier, Alstom*

# Nomex® - Applications and Benefits

## *Parallels between Aerospace and Rail*

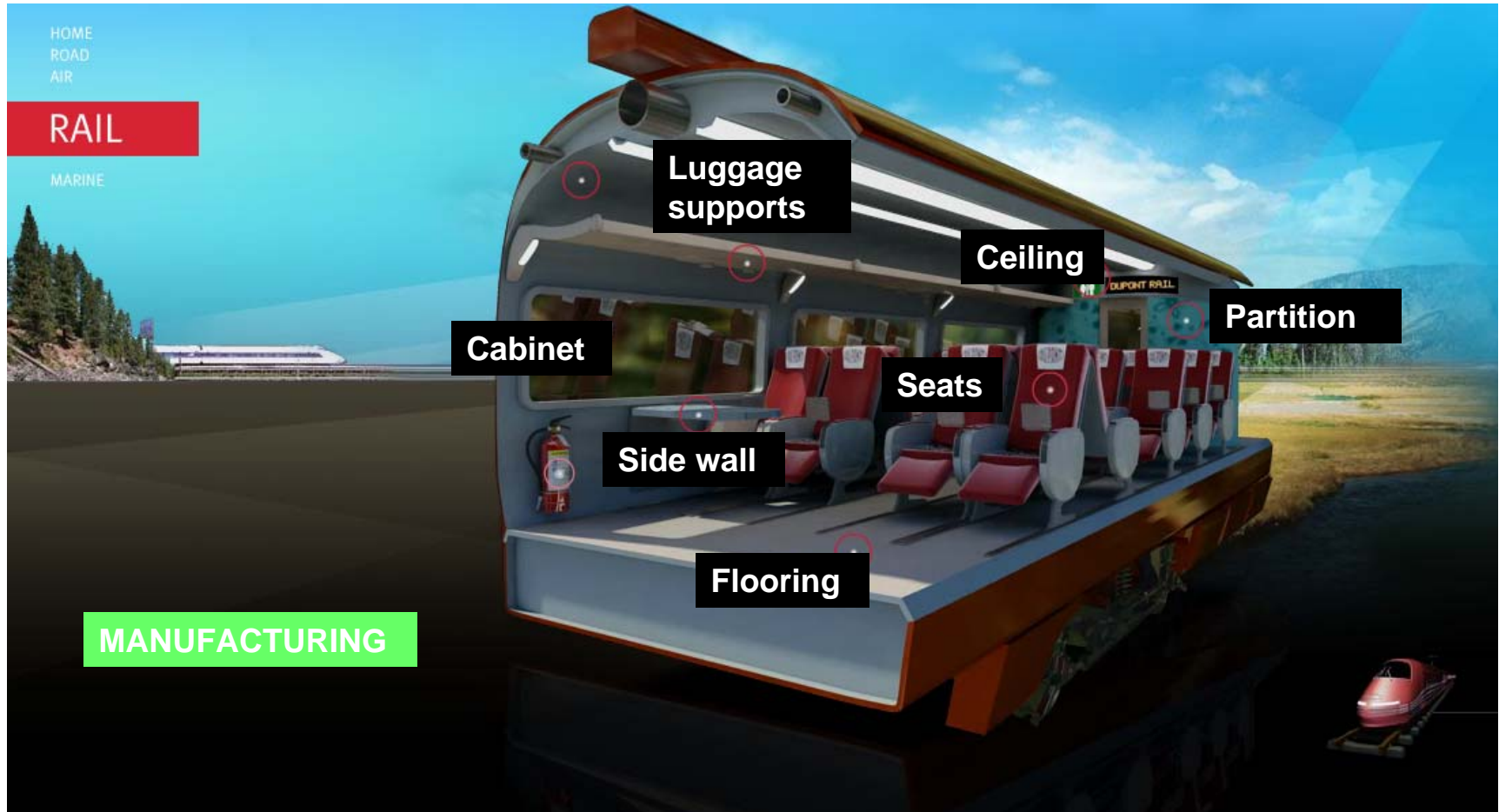

### Aerospace and Rail have same requirements:

- Similar interiors
- Same requirements and functionalities

# Nomex® - Applications and Benefits

*“Nomex® - the qualities you need in mass transportation”*

## Fabrication of Nomex® cored sandwich structures

- 3 conditions should be met
  - **Tooling and fixtures** must maintain the desired shape
  - **Uniform pressure** must be applied to hold the structure together during curing
  - **Uniform heating** must be used to cure the resin
- 3 alternative well-established production methods
  - **Heated press** – for flat boards or simple preformed panels
  - **RTM / vacuum processing** - for **large** or complex form **panels**
  - **Matched mould processing** – for batch production of finished panels



Photo courtesy of Stadler

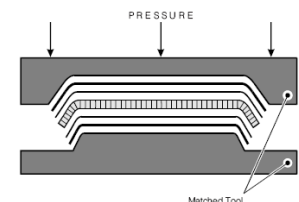
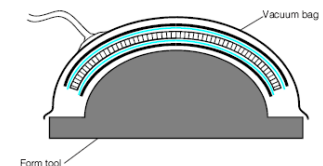
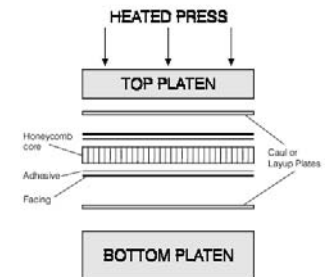

# Nomex® - Applications and Benefits

## Fabrication of Nomex® cored sandwich structures

### Benefits

- From conventional assembly to composites route:
  - **Less holes / bolts** (-40% tensile / -15% compression strength locally) for **stronger and reliable parts**
  - **More bonding** for **less stress concentration**
  - Consolidation of manufacturing with much **fewer parts**
  - Advanced **Nomex® honeycombs** suitable for RTM for **improved manufacturing efficiency** especially for **large parts** (flooring, ceiling, side-walls,...)
  - Can be combined with **Kevlar® face sheets** for **improved impact resistance** (ballast, hail, maintenance, vandalism,...) resulting in **longer life cycle** and **reduced maintenance**
  - Some **Kevlar® fabrics** are especially adapted for **RTM**

### Panel toughness comparison (number of repeated impacts)

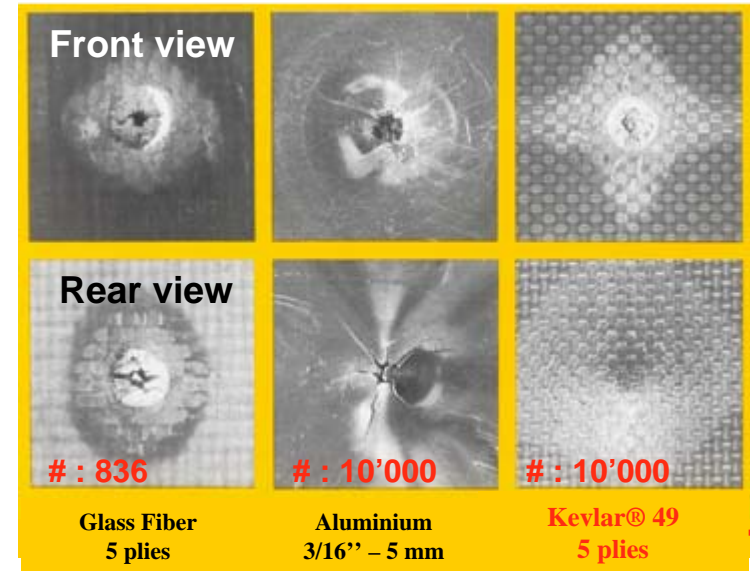

**Tough, impact resistant, puncture resistant, inherent resistance to abrasion, environmental degradation resistant, corrosion free, heat / electrical insulator, vibrations / sound damping, safety, ruggedness, reliability**



# Agenda

- **Nomex® Honeycombs for Rail Applications**
  - **Characteristics for transportation industry**
  - **Parallels between aerospace and rail**
  - **Applications and benefits**
    - **Structural**
    - **Interiors and design**
    - **Manufacturing**
- **Conclusions**



# Nomex® (and Kevlar®) for Transportation Industry

## CONCLUSIONS

### Benefits for Mass Transportation Industry

Properties	Benefits
Low density	Weight savings for increased payload, energy savings. Assists structural weight management.
High strength & stiffness	Robustness, dimensional stability under load
Impact resistance	Durability; safety
Electrically non-conductive	No galvanic corrosion; increased durability; radio transparency
Low thermal expansion	Dimensional stability
Vibration damping	Enhanced durability
Thermal insulation	Energy conservation, comfort
Resistant to heat and flames	Safety
Good weatherability	Long-term exterior use

- **Exceptional combination of many desirable engineering properties** opens many opportunities for new and better products especially for the highly weight-conscious field of transportation



As a **leading science company**, **DuPont** is a **partner of choice** with its sustainable & technology driven solutions. Bringing together high performance, aesthetics and safety, DuPont is meeting the needs of the rail industry today.



# Nomex® (and Kevlar®) for Transportation Industry

## ➤ Composite technology ladder in MT Production

Where do you stand with your technology ?

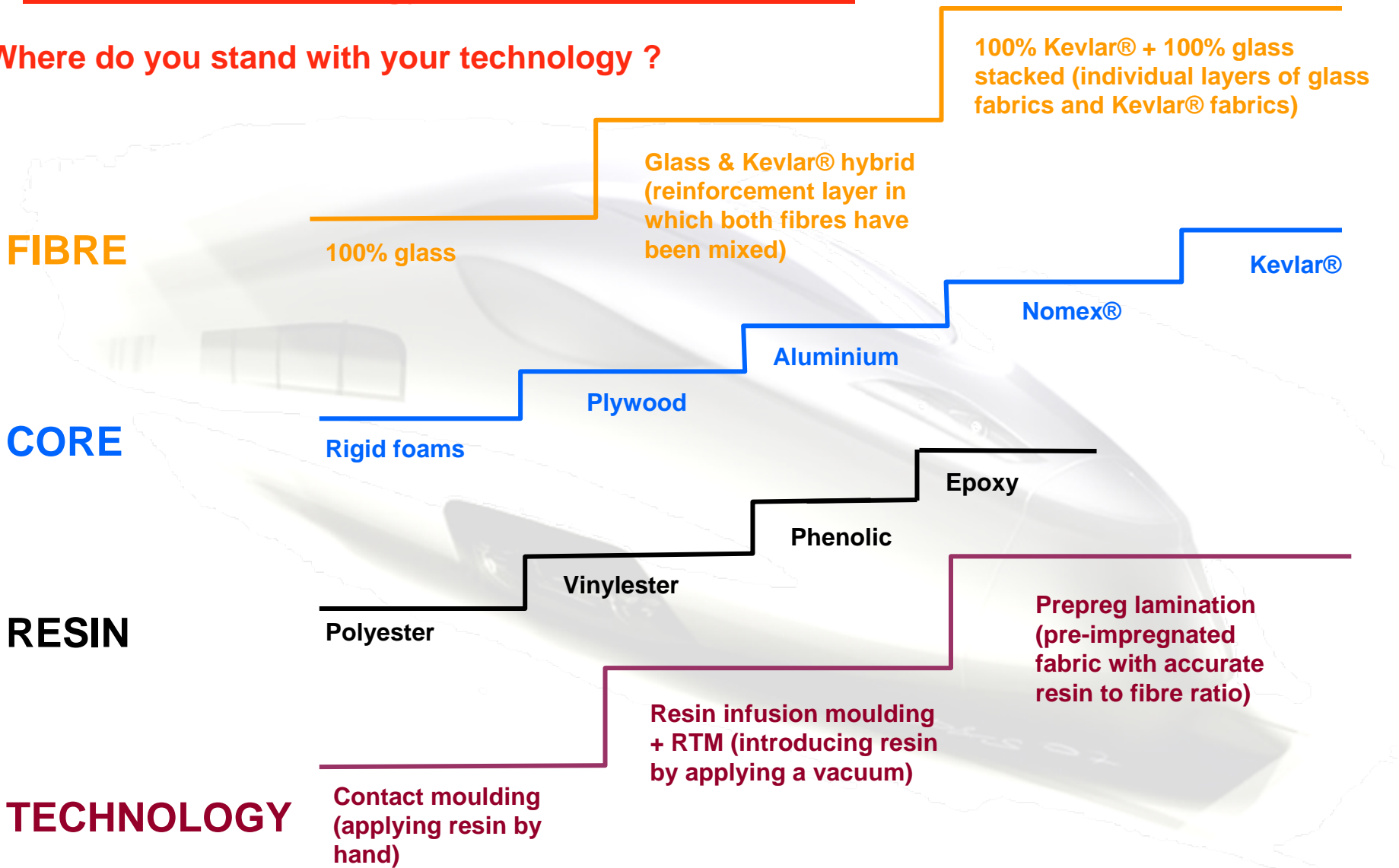



*The miracles of science™*

[www.dupont.com](http://www.dupont.com)



*The information and suggestions provided in this presentation are based on data believed to be reliable, but the DuPont Company makes no warranties express or implied as to their accuracy and assumes no responsibility or liability arising out of its use by others. Further, the information and suggestions are not intended to substitute for any testing you may need to conduct to determine for yourself the suitability of a particular material for a particular purpose. DuPont makes no guarantee of results and assumes no obligation or liability in connection with the use of the information or suggestions provided in this presentation.*